

Axis^{AX}

Network Modules

The AX-NET4 and AX-NET7 network modules meet the demands of both small and large networks, and provide the benefits of distributed intelligence and reduced installation costs.

The network can be fully fault tolerant to single opens or short circuits by using the Advanced AX-NET7 module. In addition, ground fault monitoring is standard with either style network.

The Advanced network operates as a true peer-to-peer network with full cross-node reporting. The network allows information from any input or output device to be passed over the network and displayed on any Axis AX fire alarm control panel or remote graphical LCD annunciator. Details include alarm, supervisory, warning, trouble, control events and disabled zone/points as well as analogue values, test instructions and status information.

For more complex networked systems, the Advanced Windows-based PC-NeT configuration software allows sector based programming for such functions as drill, acknowledge, silence, resound and reset control keys. All panels within the same sector can share common controls, and each fire alarm panel or remote annunciator can also be programmed to show specific network information on a zone/point basis.

The level of information displayed and the control capabilities of each network node is fully field programmable. Individual nodes can be configured to vectors information and control, allowing specific nodes to be dedicated to alarms, mass notifications, troubles, supervisory or other status events.

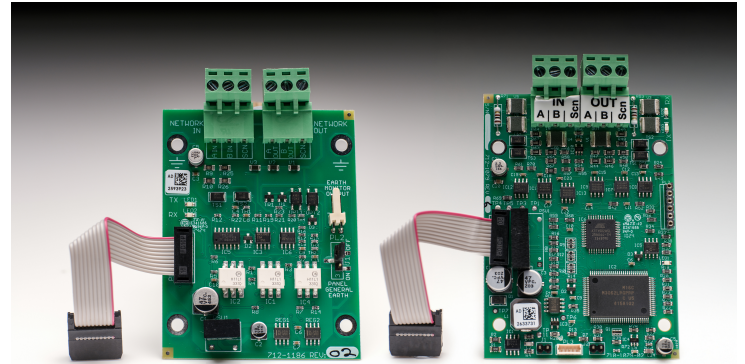

Features

- Class B or Class X(A) Network Communicators
- Peer-to-Peer Network
- Fully Fault-Tolerant Network
- Up to 5000ft Between Nodes
- In-built Network Diagnostics displaying Real-time Information
- 200 Nodes Per Network without Audio
- 150 Nodes Per Network with Audio
- Up to 1000 Shared Network Zones
- Uncomplicated and Easy Installation

Listings and Approvals

- Certified to UL864 10th Edition – File No. S35979
- CSFM Approved: Pending
- NYCFD COA: Pending

Wiring Diagrams

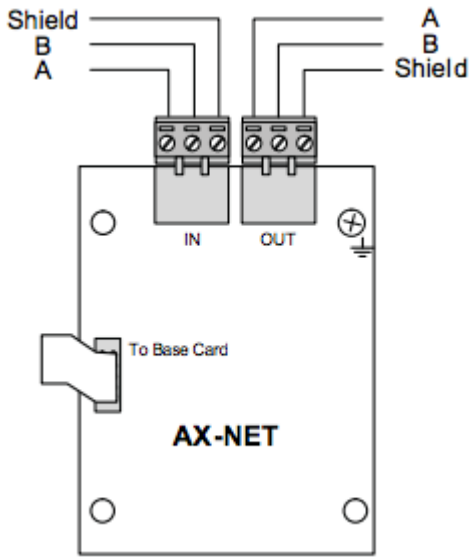

AX-NET4 & AX-NET7 Wiring Diagram

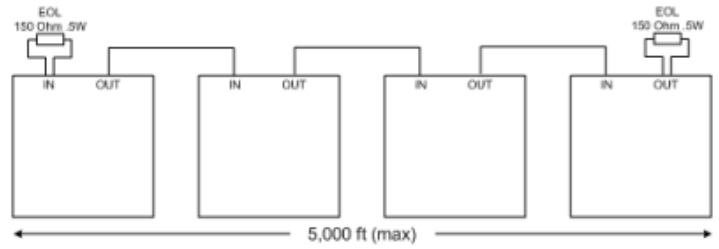

AX-NET4 Network Wiring Diagram

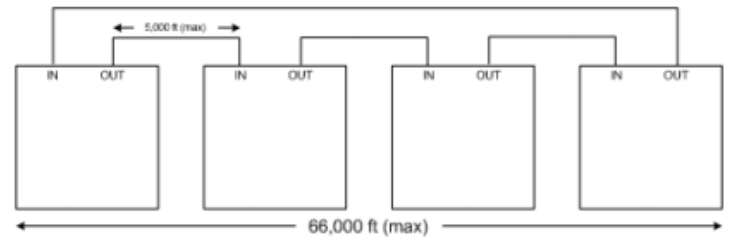

AX-NET7 Network Wiring Diagram

Specification

Operating Current (AX-NET4 & 7)	
Quiescent	62 mA
Alarm	62 mA
Environment	Indoor, Dry
Operating Temperature	32 °F-120° F (0 °C-48° C)
Humidity	10-95% (Non-condensing)
Dimensions	
AX-NET4 & AX-NET7	3½" H x x 2½" W x ½" D
Weight	
AX-NET4 & AX-NET7	1.7 oz
Nodes/Distances	
AX-NET4	32 Nodes, 5000ft Maximum (EOL 150 Ohm [both ends])
AX-NET7	200 Nodes, 5000ft Between Nodes, 66000ft maximum overall cable length
Wiring	Twisted pair 18 - 20 AWG Minimum Recommended Twisted Shielded (Belden 8760, 8762)

Ordering Codes and Options

AX-NET4	Class B Network Module
AX-NET7	Class X(A) Network Module

Check if this document is up to date | Give us feedback

9564 Yellowhead Trail NW, Edmonton AB, T5G 0W4, Canada T: 1 (866) 462-7100 E: info@harding-tech.com W: www.harding-tech.com

As our policy is one of constant product improvement the right is therefore reserved to modify product specifications without prior notice.